

NOTES: UNLESS OTHERWISE SPECIFIED

1. DIMENSIONS ARE IN INCHES.

△ DIMENSION SHOWN IS FOR 3/8-INCH HOSE FITTINGS. 1/2-INCH HOSE FITTING DIMENSION IS LARGER.

WARNING: THIS ASSEMBLY IS TO BE USED WITH VACUUM PRESSURE ONLY. SERIOUS INJURY MAY OCCUR IF GLASS BODY IS SUBJECTED TO POSITIVE INTERNAL PRESSURE!

REVISIONS				
ECO NO.	REV	DESCRIPTION	DATE	APPROVED
	XA	PROTOTYPE RELEASE		

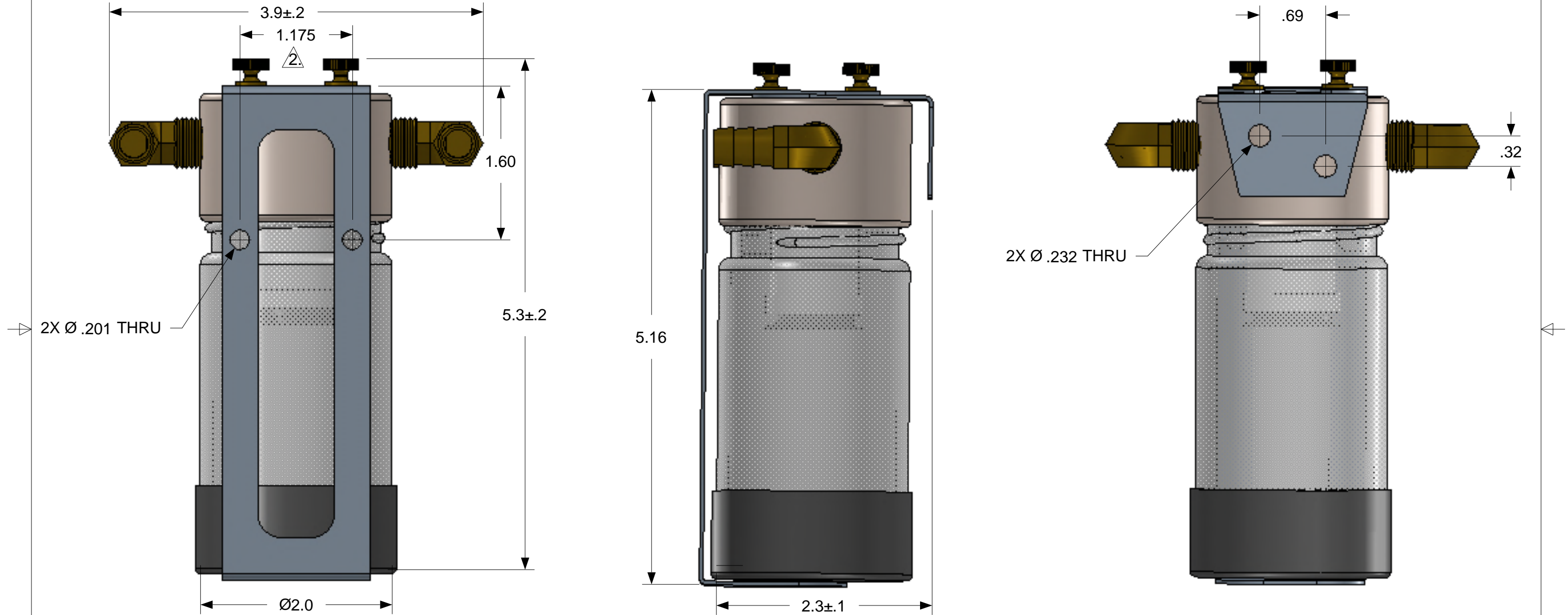

PROPRIETARY INFORMATION

This document contains information proprietary to Conceptual Polymer and shall not be disclosed, duplicated or used as a basis for design, manufacture, or sale of apparatus without express written permission of Conceptual Polymer.

THIRD ANGLE PROJECTION		UNLESS OTHERWISE SPECIFIED, DIMENSIONS ARE IN INCHES. TOLERANCES: DECIMALS: .XX ± .01	CONTRACT NO.		Conceptual Polymer 12089 Celome Ln. San Diego, CA 92129	
			APPROVALS		DATE	TITLE
		ANGLES: 1.5° DRILLED HOLES: n0- n .500: +.005 -.002	DRAWN	D. SULLI	080119	ASSY, FILTER, COALESCING/PARTICULATE, GLASS BODY VERSION
		n.501-n 1.000: +.008 -.004	DESIGNED	D. SULLI	080119	
NEXT ASSY	FINAL ASSY	DO NOT SCALE DRAWING	MFG. ENG.			SIZE B
APPLICATION			RELEASED			FSCM NO.
						DWG NO CP04PA009/010
						REV XA
						SCALE 1:1
						SHEET 1 OF 1